

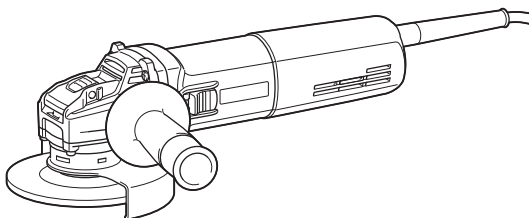

EN	Angle Grinder	INSTRUCTION MANUAL	6
FR	Meuleuse d'Angle	MANUEL D'INSTRUCTIONS	16
DE	Winkelschleifer	BETRIEBSANLEITUNG	27
IT	Smerigliatrice angolare	ISTRUZIONI PER L'USO	38
NL	Haakse slijpmachine	GEBRUIKSAANWIJZING	49
ES	Esmeriladora Angular	MANUAL DE INSTRUCCIONES	60
PT	Esmerilhadeira Angular	MANUAL DE INSTRUÇÕES	71
DA	Vinkelsliber	BRUGSANVISNING	82
EL	Γωνιακός λειαντήρας	ΕΓΧΕΙΡΙΔΙΟ ΟΔΗΓΙΩΝ	92
TR	Taşlama Makinası	KULLANMA KILAVUZU	103

GA5080 GA5080R



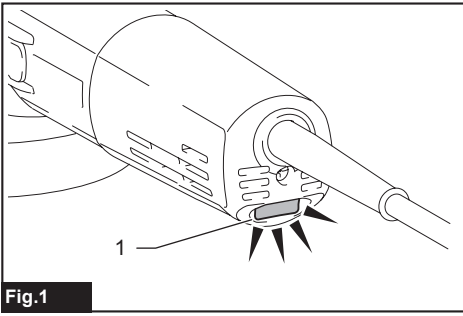

Fig.1

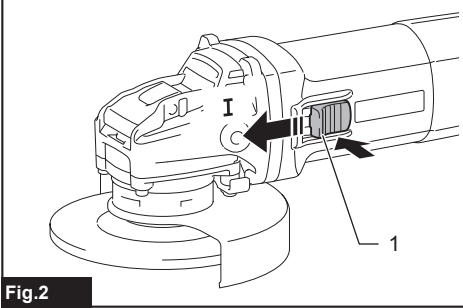

Fig.2

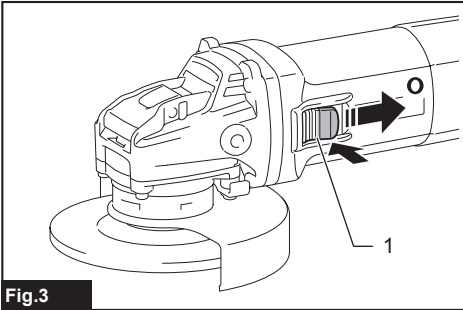

Fig.3

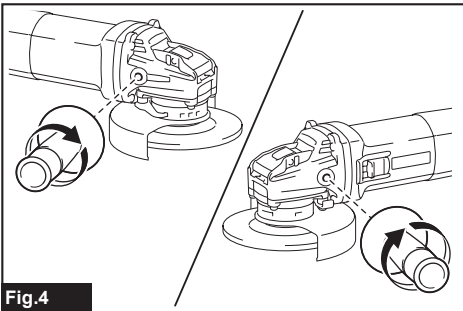

Fig.4

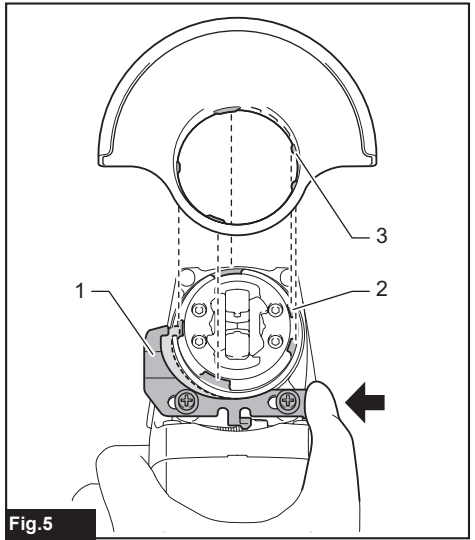

Fig.5

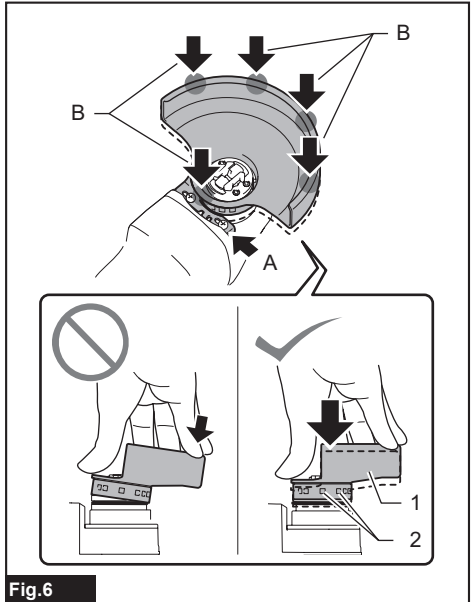

Fig.6

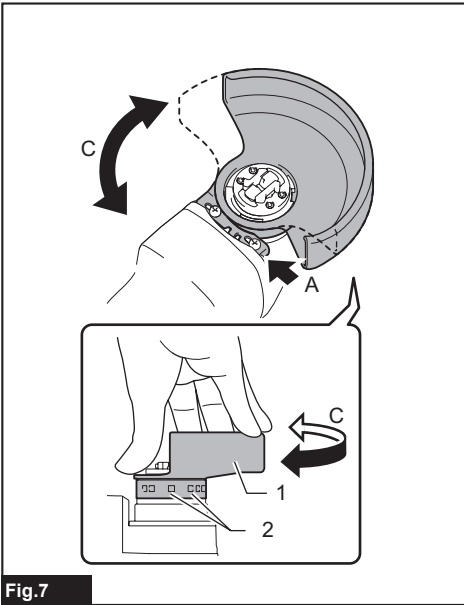

Fig.7

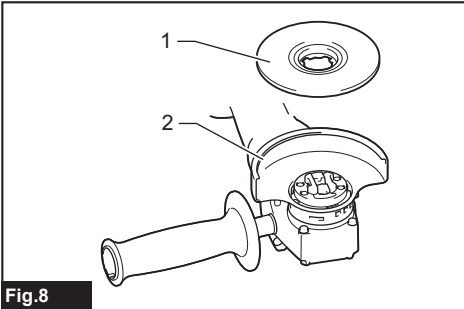

Fig.8

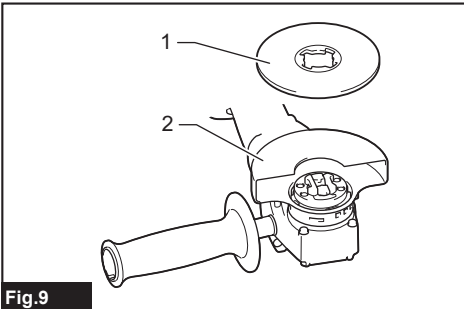

Fig.9

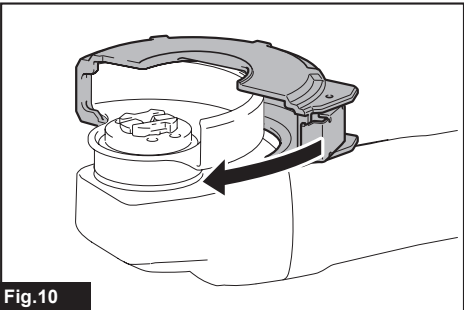

Fig.10

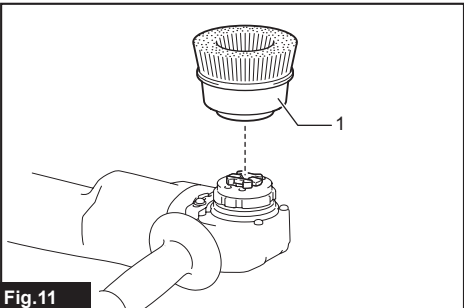

Fig.11

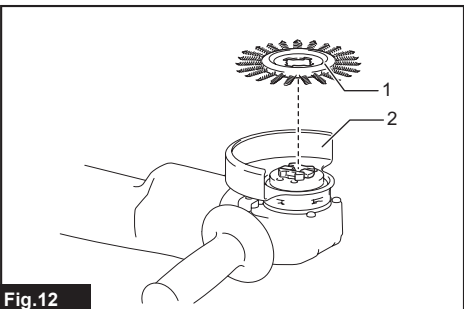
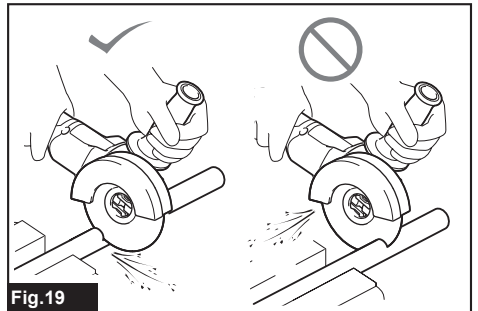
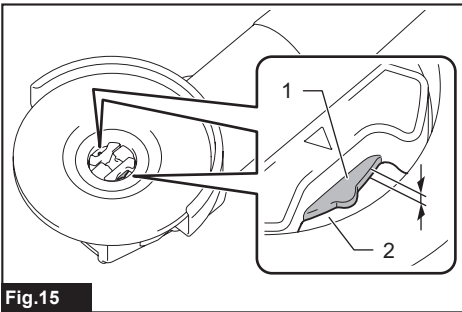
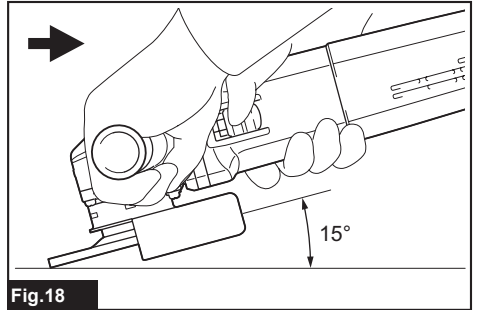
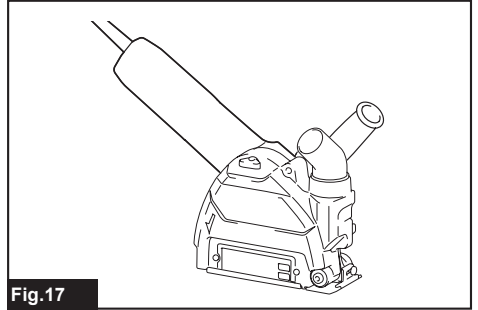
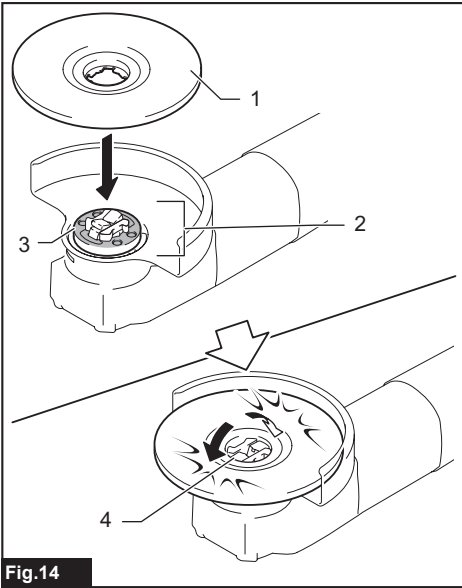
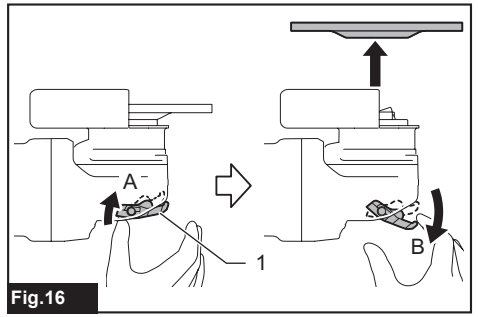
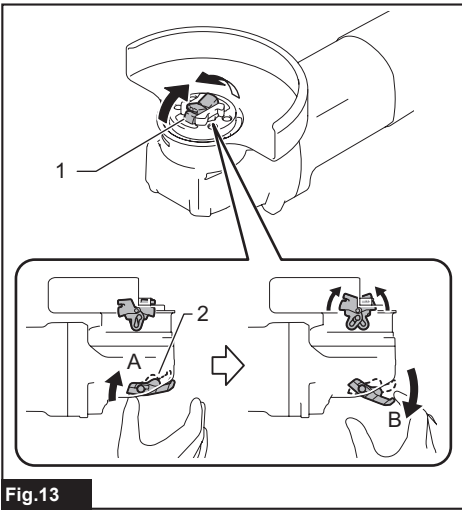

Fig.12



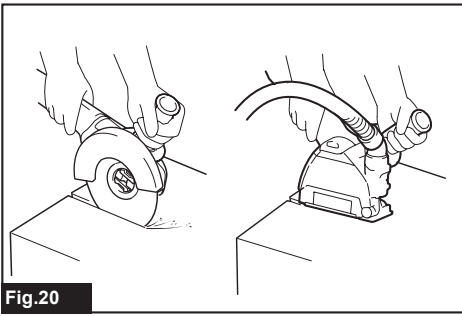

Fig.20

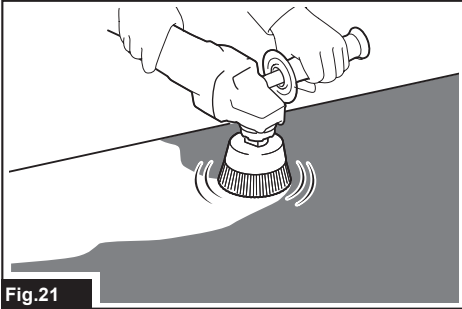

Fig.21

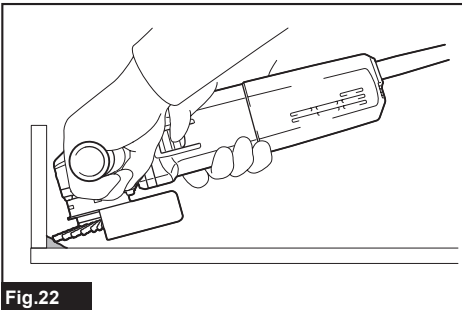

Fig.22

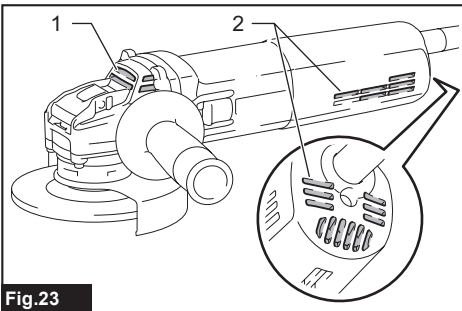

Fig.23





SPECIFICATIONS

Model:		GA5080	GA5080R
Applicable grinding wheel	Max. wheel diameter	125 mm	
	Max. wheel thickness	6 mm	
Applicable cut-off wheel	Max. wheel diameter	125 mm	
	Max. wheel thickness	1.6 mm	
Applicable wire wheel brush	Max. wheel diameter	115 mm	
	Max. wheel thickness	16 mm	
No load speed (n ₀) / Rated speed (n)		12,000 min ⁻¹	
Overall length		309 mm	
Net weight		2.5 - 3.6 kg	
Safety class		□/II	

- Due to our continuing program of research and development, the specifications herein are subject to change without notice.
- Specifications may differ from country to country.
- The weight may differ depending on the attachment(s). The lightest and heaviest combinations, according to EPTA-Procedure 01/2014, are shown in the table.

Symbols

The followings show the symbols which may be used for the equipment. Be sure that you understand their meaning before use.

	Read instruction manual.
	Wear safety glasses.
	Always operate with two hands.
	Do not use the wheel guard for cut-off operations.
	DOUBLE INSULATION



Only for EU countries
Due to the presence of hazardous components in the equipment, used electrical and electronic equipment may have a negative impact on the environment and human health.

Do not dispose of electrical and electronic appliances with household waste!

In accordance with the European Directive on waste electrical and electronic equipment and its adaptation to national law, used electrical and electronic equipment should be collected separately and delivered to a separate collection point for municipal waste, operating in accordance with the environmental protection regulations.

This is indicated by the symbol of the crossed-out wheeled bin placed on the equipment.

Intended use

The tool is intended for grinding, sanding, wire brushing and cutting of metal and stone materials without the use of water.

Power supply

The tool should be connected only to a power supply of the same voltage as indicated on the nameplate, and can only be operated on single-phase AC supply. They are double-insulated and can, therefore, also be used from sockets without earth wire.

Noise

The typical A-weighted noise level determined according to EN62841-2-3:

Model	Sound pressure level (L_{pA}) : (dB(A))	Sound power level (L_{WA}) : (dB(A))	Uncertainty (K) : (dB(A))
GA5080	87	95	3
GA5080R	87	95	3

NOTE: The declared noise emission value(s) has been measured in accordance with a standard test method and may be used for comparing one tool with another.

NOTE: The declared noise emission value(s) may also be used in a preliminary assessment of exposure.

⚠WARNING: Wear ear protection.

⚠WARNING: The noise emission during actual use of the power tool can differ from the declared value(s) depending on the ways in which the tool is used especially what kind of workpiece is processed.

⚠WARNING: Be sure to identify safety measures to protect the operator that are based on an estimation of exposure in the actual conditions of use (taking account of all parts of the operating cycle such as the times when the tool is switched off and when it is running idle in addition to the trigger time).

⚠WARNING: Grinding thin sheets of metal or other easily vibrating structures with a large surface can result in a total noise emission much higher (up to 15 dB) than the declared noise emission values.

Set heavy flexible damping mats or such to those workpieces to prevent them from emitting sound.

Take the increased noise emission into consideration for both the risk assessment of noise exposure and selecting adequate hearing protection.

Vibration

The vibration total value (tri-axial vector sum) determined according to EN62841-2-3:

Work mode: surface grinding with normal side grip

Model	Vibration emission ($a_{hv, AG}$) : (m/s^2)	Uncertainty (K) : (m/s^2)
GA5080	7.9	1.5
GA5080R	7.9	1.5

Work mode: surface grinding with anti vibration side grip

Model	Vibration emission ($a_{hv, AG}$) : (m/s^2)	Uncertainty (K) : (m/s^2)
GA5080	6.6	1.5
GA5080R	6.6	1.5

Work mode: disc sanding with normal side grip

Model	Vibration emission ($a_{hv, DS}$) : (m/s^2)	Uncertainty (K) : (m/s^2)
GA5080	3.4	1.5
GA5080R	3.4	1.5

Work mode: disc sanding with anti vibration side grip

Model	Vibration emission ($a_{hv, DS}$) : (m/s^2)	Uncertainty (K) : (m/s^2)
GA5080	4.7	1.5
GA5080R	4.7	1.5

NOTE: The declared vibration total value(s) has been measured in accordance with a standard test method and may be used for comparing one tool with another.

NOTE: The declared vibration total value(s) may also be used in a preliminary assessment of exposure.

⚠️WARNING: The vibration emission during actual use of the power tool can differ from the declared value(s) depending on the ways in which the tool is used especially what kind of workpiece is processed.

⚠️WARNING: Be sure to identify safety measures to protect the operator that are based on an estimation of exposure in the actual conditions of use (taking account of all parts of the operating cycle such as the times when the tool is switched off and when it is running idle in addition to the trigger time).

⚠️WARNING: The declared vibration emission value is used for main applications of the power tool. However if the power tool is used for other applications, the vibration emission value may be different.

EC Declaration of Conformity

For European countries only

The EC declaration of conformity is included as Annex A to this instruction manual.

SAFETY WARNINGS

General power tool safety warnings

⚠️WARNING Read all safety warnings, instructions, illustrations and specifications provided with this power tool. Failure to follow all instructions listed below may result in electric shock, fire and/or serious injury.

Save all warnings and instructions for future reference.

The term "power tool" in the warnings refers to your mains-operated (corded) power tool or battery-operated (cordless) power tool.

Grinder safety warnings

Safety warnings common for grinding, sanding, wire brushing, or cutting-off operations:

- 1. This power tool is intended to function as a grinder, sander, wire brush, or cut-off tool.** Read all safety warnings, instructions and specifications provided with this power tool. Failure to follow all instructions listed below may result in electric shock, fire and/or serious injury.
- 2. Operations such as polishing or hole cutting are not to be performed with this power tool.** Operations for which the power tool was not designed may create a hazard and cause personal injury.
- 3. Do not convert this power tool to operate in a way which is not specifically designed and specified by the tool manufacturer.** Such a conversion may result in a loss of control and cause serious personal injury.
- 4. Do not use accessories which are not specifically designed and specified by the tool manufacturer.** Just because the accessory can be attached to your power tool, it does not assure safe operation.
- 5. The rated speed of the accessory must be at least equal to the maximum speed marked on the power tool.** Accessories running faster than their rated speed can break and fly apart.
- 6. The outside diameter and the thickness of your accessory must be within the capacity rating of your power tool.** Incorrectly sized accessories cannot be adequately guarded or controlled.
- 7. The dimensions of the accessory mounting must fit the dimensions of the mounting hardware of the power tool.** Accessories that do not match the mounting hardware of the power tool will run out of balance, vibrate excessively and may cause loss of control.
- 8. Do not use a damaged accessory. Before each use inspect the accessory such as abrasive wheels for chips and cracks, backing pad for cracks, tear or excess wear, wire brush for loose or cracked wires. If power tool or accessory is dropped, inspect for damage or install an undamaged accessory. After inspecting and installing an accessory, position yourself and bystanders away from the plane of the rotating accessory and run the power tool at maximum no-load speed for one minute.** Damaged accessories will normally break apart during this test time.
- 9. Wear personal protective equipment. Depending on application, use face shield, safety goggles or safety glasses. As appropriate, wear dust mask, hearing protectors, gloves and workshop apron capable of stopping small abrasive or workpiece fragments.** The eye protection must be capable of stopping flying debris generated by various applications. The dust mask or respirator must be capable of filtering particles generated by the particular application. Prolonged exposure to high intensity noise may cause hearing loss.
- 10. Keep bystanders a safe distance away from work area. Anyone entering the work area must wear personal protective equipment.** Fragments of workpiece or of a broken accessory may fly away and cause injury beyond immediate area of operation.
- 11. Hold the power tool by insulated gripping surfaces only, when performing an operation where the cutting accessory may contact hidden wiring or its own cord.** Cutting accessory contacting a "live" wire may make exposed metal parts of the power tool "live" and could give the operator an electric shock.
- 12. Position the cord clear of the spinning accessory.** If you lose control, the cord may be cut or snagged and your hand or arm may be pulled into the spinning accessory.
- 13. Never lay the power tool down until the accessory has come to a complete stop.** The spinning accessory may grab the surface and pull the power tool out of your control.

14. **Do not run the power tool while carrying it at your side.** Accidental contact with the spinning accessory could snag your clothing, pulling the accessory into your body.
 15. **Regularly clean the power tool's air vents.** The motor's fan will draw the dust inside the housing and excessive accumulation of powdered metal may cause electrical hazards.
 16. **Do not operate the power tool near flammable materials.** Sparks could ignite these materials.
 17. **Do not use accessories that require liquid coolants.** Using water or other liquid coolants may result in electrocution or shock.
3. **The guard must be securely attached to the power tool and positioned for maximum safety, so the least amount of wheel is exposed towards the operator.** The guard helps to protect the operator from broken wheel fragments, accidental contact with wheel and sparks that could ignite clothing.
 4. **Wheels must be used only for specified applications. For example: do not grind with the side of cut-off wheel.** Abrasive cut-off wheels are intended for peripheral grinding, side forces applied to these wheels may cause them to shatter.
 5. **Always use undamaged wheel flanges that are of correct size and shape for your selected wheel.** Proper wheel flanges support the wheel thus reducing the possibility of wheel breakage. Flanges for cut-off wheels may be different from grinding wheel flanges.
 6. **Do not use worn down wheels from larger power tools.** A wheel intended for larger power tool is not suitable for the higher speed of a smaller tool and may burst.
 7. **When using dual purpose wheels always use the correct guard for the application being performed.** Failure to use the correct guard may not provide the desired level of guarding, which could lead to serious injury.

Kickback and related warnings:

Kickback is a sudden reaction to a pinched or snagged rotating wheel, backing pad, brush or any other accessory. Pinching or snagging causes rapid stalling of the rotating accessory which in turn causes the uncontrolled power tool to be forced in the direction opposite of the accessory's rotation at the point of the binding. For example, if an abrasive wheel is snagged or pinched by the workpiece, the edge of the wheel that is entering into the pinch point can dig into the surface of the material causing the wheel to climb out or kick out. The wheel may either jump toward or away from the operator, depending on direction of the wheel's movement at the point of pinching. Abrasive wheels may also break under these conditions.

Kickback is the result of power tool misuse and/or incorrect operating procedures or conditions and can be avoided by taking proper precautions as given below.

1. **Maintain a firm grip with both hands on the power tool and position your body and arms to allow you to resist kickback forces. Always use auxiliary handle, if provided, for maximum control over kickback or torque reaction during start-up.** The operator can control torque reactions or kickback forces, if proper precautions are taken.
2. **Never place your hand near the rotating accessory.** Accessory may kickback over your hand.
3. **Do not position your body in the area where power tool will move if kickback occurs.** Kickback will propel the tool in direction opposite to the wheel's movement at the point of snagging.
4. **Use special care when working corners, sharp edges, etc. Avoid bouncing and snagging the accessory.** Corners, sharp edges or bouncing have a tendency to snag the rotating accessory and cause loss of control or kickback.
5. **Do not attach a saw chain woodcarving blade, segmented diamond wheel with a peripheral gap greater than 10 mm or toothed saw blade.** Such blades create frequent kickback and loss of control.

Safety warnings specific for grinding and cutting-off operations:

1. **Use only wheel types that are specified for your power tool and the specific guard designed for the selected wheel.** Wheels for which the power tool was not designed cannot be adequately guarded and are unsafe.
2. **The grinding surface of centre depressed wheels must be mounted below the plane of the guard lip.** An improperly mounted wheel that projects through the plane of the guard lip cannot be adequately protected.

1. **Do not "jam" the cut-off wheel or apply excessive pressure. Do not attempt to make an excessive depth of cut.** Overstressing the wheel increases the loading and susceptibility to twisting or binding of the wheel in the cut and the possibility of kickback or wheel breakage.
2. **Do not position your body in line with and behind the rotating wheel.** When the wheel, at the point of operation, is moving away from your body, the possible kickback may propel the spinning wheel and the power tool directly at you.
3. **When the wheel is binding or when interrupting a cut for any reason, switch off the power tool and hold it motionless until the wheel comes to a complete stop. Never attempt to remove the cut-off wheel from the cut while the wheel is in motion otherwise kickback may occur.** Investigate and take corrective action to eliminate the cause of wheel binding.
4. **Do not restart the cutting operation in the workpiece. Let the wheel reach full speed and carefully re-enter the cut.** The wheel may bind, walk up or kickback if the power tool is restarted in the workpiece.
5. **Support panels or any oversized workpiece to minimize the risk of wheel pinching and kickback.** Large workpieces tend to sag under their own weight. Supports must be placed under the workpiece near the line of cut and near the edge of the workpiece on both sides of the wheel.
6. **Use extra caution when making a "pocket cut" into existing walls or other blind areas.** The protruding wheel may cut gas or water pipes, electrical wiring or objects that can cause kickback.

Additional safety warnings specific for cutting-off operations:

1. **Do not "jam" the cut-off wheel or apply excessive pressure. Do not attempt to make an excessive depth of cut.** Overstressing the wheel increases the loading and susceptibility to twisting or binding of the wheel in the cut and the possibility of kickback or wheel breakage.
2. **Do not position your body in line with and behind the rotating wheel.** When the wheel, at the point of operation, is moving away from your body, the possible kickback may propel the spinning wheel and the power tool directly at you.
3. **When the wheel is binding or when interrupting a cut for any reason, switch off the power tool and hold it motionless until the wheel comes to a complete stop. Never attempt to remove the cut-off wheel from the cut while the wheel is in motion otherwise kickback may occur.** Investigate and take corrective action to eliminate the cause of wheel binding.
4. **Do not restart the cutting operation in the workpiece. Let the wheel reach full speed and carefully re-enter the cut.** The wheel may bind, walk up or kickback if the power tool is restarted in the workpiece.
5. **Support panels or any oversized workpiece to minimize the risk of wheel pinching and kickback.** Large workpieces tend to sag under their own weight. Supports must be placed under the workpiece near the line of cut and near the edge of the workpiece on both sides of the wheel.
6. **Use extra caution when making a "pocket cut" into existing walls or other blind areas.** The protruding wheel may cut gas or water pipes, electrical wiring or objects that can cause kickback.

7. **Do not attempt to do curved cutting.**
Overstressing the wheel increases the loading and susceptibility to twisting or binding of the wheel in the cut and the possibility of kickback or wheel breakage, which can lead to serious injury.
8. **Before using a segmented diamond wheel, make sure that the diamond wheel has the peripheral gap between segments of 10 mm or less, only with a negative rake angle.**

Safety warnings specific for sanding operations:

1. **Use proper sized sanding disc paper. Follow manufacturers recommendations, when selecting sanding paper.** Larger sanding paper extending too far beyond the sanding pad presents a laceration hazard and may cause snagging, tearing of the disc or kickback.

Safety warnings specific for wire brushing operations:

1. **Be aware that wire bristles are thrown by the brush even during ordinary operation. Do not overstress the wires by applying excessive load to the brush.** The wire bristles can easily penetrate light clothing and/or skin.
2. **If the use of a guard is specified for wire brushing, do not allow any interference of the wire wheel or brush with the guard.** Wire wheel or brush may expand in diameter due to work load and centrifugal forces.

Additional Safety Warnings:

1. **When using depressed centre grinding wheels, be sure to use only fiberglass-reinforced wheels.**
2. **NEVER USE Stone Cup type wheels with this grinder.** This grinder is not designed for these types of wheels and the use of such a product may result in serious personal injury.
3. **Be careful not to damage the X-LOCK holder.** Damage to the parts could result in wheel breakage.
4. **Make sure the wheel is not contacting the workpiece before the switch is turned on.**
5. **Before using the tool on an actual workpiece, let it run for a while. Watch for vibration or wobbling that could indicate poor installation or a poorly balanced wheel.**
6. **Use the specified surface of the wheel to perform the grinding.**
7. **Do not leave the tool running. Operate the tool only when hand-held.**
8. **Do not touch the workpiece immediately after operation; it may be extremely hot and could burn your skin.**
9. **Do not touch accessories immediately after operation; it may be extremely hot and could burn your skin.**
10. **Observe the instructions of the manufacturer for correct mounting and use of wheels.** Handle and store wheels with care.
11. **Do not use separate reducing bushings or adaptors to adapt large hole abrasive wheels.**
12. **Check that the workpiece is properly supported.**
13. **Pay attention that the wheel continues to rotate after the tool is switched off.**

14. **If working place is extremely hot and humid, or badly polluted by conductive dust, use a short-circuit breaker (30 mA) to assure operator safety.**
15. **Do not use the tool on any materials containing asbestos.**
16. **When use cut-off wheel, always work with the dust collecting wheel guard if required by domestic regulation.**
17. **Cutting discs must not be subjected to any lateral pressure.**
18. **Do not use cloth work gloves during operation.** Fibers from cloth gloves may enter the tool, which causes tool breakage.
19. **Before operation, make sure that there is no buried object such as electric pipe, water pipe or gas pipe in the workpiece.** Otherwise, it may cause an electric shock, electrical leakage or gas leak.

SAVE THESE INSTRUCTIONS.

⚠WARNING: DO NOT let comfort or familiarity with product (gained from repeated use) replace strict adherence to safety rules for the subject product. MISUSE or failure to follow the safety rules stated in this instruction manual may cause serious personal injury.

FUNCTIONAL DESCRIPTION

⚠CAUTION: Always be sure that the tool is switched off and unplugged before adjusting or checking function on the tool.

Indication lamp

Only for model GA5080R

► Fig.1: 1. Indication lamp

The indication lamp lights up green when the tool is plugged.

If the indication lamp does not light up, the mains cord or the controller may be defective.

The indication lamp is lit but the tool does not start even if the tool is switched on, the carbon brushes may be worn out, or the controller, the motor or the ON/OFF switch may be defective.

Switch action

⚠CAUTION: Before plugging in the tool, always check to see that the slide switch actuates properly and returns to the "OFF" position when the rear end of the slide switch is depressed.

⚠CAUTION: Switch can be locked in the "ON" position for ease of operator comfort during extended use. Apply caution when locking tool in the "ON" position and maintain firm grasp on tool.

To start the tool, press down the rear end of the slide switch and then slide it toward the "I (ON)" position. For continuous operation, press down the front end of the slide switch to lock it.

► **Fig.2:** 1. Slide switch

To stop the tool, press down the rear end of the slide switch so that it returns to the "O (OFF)" position.

► **Fig.3:** 1. Slide switch

Accidental re-start preventive function

Only for model GA5080R

When plugging in the tool while the switch is ON, the tool does not start.

At this time, the indication lamp blinks in red and shows that the accidental re-start preventive function works.

To start the tool, turn off the switch, and turn it on again.

Soft start feature

Soft start feature reduces starting reaction.

Constant speed control

Possible to get fine finish, because the rotating speed is kept constantly even under the loaded condition.

Overload protector

When the load on the tool exceeds admissible levels, power to the motor is reduced to protect the motor from overheating. When the load returns to admissible levels, the tool will operate as normal.

ASSEMBLY

CAUTION: Always be sure that the tool is switched off and unplugged before carrying out any work on the tool.

Installing side grip (handle)

CAUTION: Always be sure that the side grip is installed securely before operation.

Screw the side grip securely on the position of the tool as shown in the figure.

► **Fig.4**

Installing or removing wheel guard

WARNING: When using a depressed center wheel, flap disc or wire wheel brush, the wheel guard must be fitted on the tool so that the closed side of the guard always points toward the operator.

WARNING: Make sure that the wheel guard is securely locked by the lock lever with one of the holes on the wheel guard.

WARNING: When using an abrasive cut-off / diamond wheel, be sure to use only the special wheel guard designed for use with cut-off wheels.

For depressed center wheel, flap disc, wire wheel brush / abrasive cut-off wheel, diamond wheel

1. While pushing the lock lever, mount the wheel guard with the protrusions on the wheel guard aligned with the notches on the bearing box.

► **Fig.5:** 1. Lock lever 2. Notch 3. Protrusion

2. While pushing the lock lever toward A, hold down the portions B of the wheel guard as shown in the figure.

► **Fig.6:** 1. Wheel guard 2. Hole

NOTE: Push down the wheel guard straight. Otherwise, you cannot secure the wheel guard.

3. While pushing the lock lever toward A, rotate the wheel guard toward C, and then, change the angle of the wheel guard according to the work so that the operator can be protected. Align the lock lever with one of the holes in the wheel guard, and then release the lock lever to lock the wheel guard.

► **Fig.7:** 1. Wheel guard 2. Hole

To remove wheel guard, follow the installation procedure in reverse.

Installing depressed center wheel or flap disc

Optional accessory

WARNING: When using a depressed center wheel or a flap disc, the wheel guard must be fitted on the tool so that the closed side of the guard always points toward the operator.

► **Fig.8:** 1. Depressed center wheel 2. Wheel guard

Installing abrasive cut-off / diamond wheel

Optional accessory

WARNING: When using an abrasive cut-off / diamond wheel, be sure to use only the special wheel guard designed for use with cut-off wheels.

WARNING: NEVER use cut-off wheel for side grinding.

► **Fig.9:** 1. Abrasive cut-off wheel / diamond wheel
2. Wheel guard for abrasive cut-off wheel / diamond wheel

Clip-on cutting wheel guard attachment

Optional accessory

NOTE: For cutting-off operations, a clip-on cutting wheel guard attachment can be used with the wheel guard (for grinding wheel).

Not available in some countries.

► **Fig.10**

Installing wire cup brush

Optional accessory

CAUTION: Do not use wire cup brush that is damaged, or which is out of balance. Use of damaged brush could increase potential for injury from contact with broken brush wires.

► Fig.11: 1. Wire cup brush

Installing wire wheel brush

Optional accessory

CAUTION: Do not use wire wheel brush that is damaged, or which is out of balance. Use of damaged wire wheel brush could increase potential for injury from contact with broken wires.

CAUTION: ALWAYS use guard with wire wheel brushes, assuring diameter of wheel fits inside guard. Wheel can shatter during use and guard helps to reduce chances of personal injury.

► Fig.12: 1. Wire wheel brush 2. Wheel guard

Installing or removing X-LOCK wheel

Optional accessory

WARNING: Never actuate the release lever of the X-LOCK holder during operation. Make sure that the X-LOCK wheel has stopped completely when removing it. Otherwise, the X-LOCK wheel comes off from the tool and may cause serious injury.

CAUTION: Use only original X-LOCK wheels with the X-LOCK logo. This tool is dedicated to X-LOCK.

The maximum clamping gauge of 1.6 mm can only be guaranteed with original X-LOCK wheels.

Use of any other wheels may lead to insecure clamping, and cause the clamp tool to come loose.

CAUTION: Do not touch the X-LOCK wheel immediately after operation. It may be extremely hot and could burn your skin.

CAUTION: Make sure that the X-LOCK wheel and holder of the tool are not deformed and are free from dust or foreign matters.

CAUTION: Do not put your finger near the holder while installing or removing the X-LOCK wheel. It may pinch your finger.

CAUTION: Do not put your finger near the release lever while installing the X-LOCK wheel. It may pinch your finger.

NOTE: No additional parts such as inner flanges or lock nuts are required to install or remove the X-LOCK wheels.

1. To install the X-LOCK wheel, make sure that both catches are in the unlocked position. If not, push the release lever from A side to lift B side, then pull the release lever from B side as illustrated. The catches are set in the unlocked position.

► Fig.13: 1. Catch 2. Release lever

2. Place a central position of the X-LOCK wheel on the holder. Make sure the X-LOCK wheel is parallel to the flange surface and with the correct side facing up.
3. Push the X-LOCK wheel into the holder. The catches snap into the lock position with a click and fix the X-LOCK wheel.

► Fig.14: 1. X-LOCK wheel 2. Holder 3. Flange surface 4. Catch

4. Make sure the X-LOCK wheel is fixed correctly. The surface of the X-LOCK wheel is no higher than the surface of the holder as shown in the figure. If not, the holder must be cleaned or the X-LOCK wheel must not be used.

► Fig.15: 1. Surface of the holder 2. Surface of the X-LOCK wheel

To remove the X-LOCK wheel, push the release lever from A side to lift B side, then pull the release lever from B side as illustrated.

The X-LOCK wheel is released and can be removed.

► Fig.16: 1. Release lever

Installing dust collecting wheel guard for cutting-off

Optional accessory

With optional accessories, you can use this tool for cutting stone materials.

► Fig.17

NOTE: For information how to install the dust collecting wheel guard, refer to the manual of the dust collecting wheel guard.

Installing or removing dust cover attachment

Optional accessory

CAUTION: Always be sure that the tool is switched off and unplugged before installing or removing the dust cover attachment. Failure to do so causes damage to the tool or a personal injury.

Install the dust cover attachment to each specified position.

For details, refer to the instruction manual of the dust cover attachment.

NOTICE: Clean out the dust cover attachment when it is clogged with dust or foreign matters. Continuing operation with a clogged dust cover attachment will damage the tool.

OPERATION

⚠ WARNING: It should never be necessary to force the tool. The weight of the tool applies adequate pressure. Forcing and excessive pressure could cause dangerous wheel breakage.

⚠ WARNING: ALWAYS replace wheel if tool is dropped while grinding.

⚠ WARNING: NEVER hit the workpiece with the wheel.

⚠ WARNING: Avoid bouncing and snagging the wheel, especially when working corners, sharp edges etc. This can cause loss of control and kickback.

⚠ WARNING: NEVER use tool with wood cutting blades and other saw blades. Such blades when used on a grinder frequently kick and cause loss of control leading to personal injury.

⚠ WARNING: Never actuate the release lever of the X-LOCK holder during operation. The X-LOCK wheel comes off from the tool and may cause serious injury.

⚠ WARNING: Make sure that the X-LOCK wheel is fixed firmly.

⚠ CAUTION: Never switch on the tool when it is in contact with the workpiece, it may cause an injury to operator.

⚠ CAUTION: Always wear safety goggles or a face shield during operation.

⚠ CAUTION: After operation, always switch off the tool and wait until the wheel has come to a complete stop before putting the tool down.

⚠ CAUTION: ALWAYS hold the tool firmly with one hand on housing and the other on the side grip (handle).

Grinding and sanding operation

► Fig.18

Turn the tool on and then apply the wheel or disc to the workpiece.

In general, keep the edge of the wheel or disc at an angle of about 15° to the workpiece surface.

During the break-in period with a new wheel, do not work the grinder in forward direction or it may cut into the workpiece. Once the edge of the wheel has been rounded off by use, the wheel may be worked in both forward and backward direction.

Operation with abrasive cut-off / diamond wheel

Optional accessory

⚠ WARNING: Do not "jam" the wheel or apply excessive pressure. Do not attempt to make an excessive depth of cut. Overstressing the wheel increases the loading and susceptibility to twisting or binding of the wheel in the cut and the possibility of kickback, wheel breakage and overheating of the motor may occur.

⚠ WARNING: Do not start the cutting operation in the workpiece. Let the wheel reach full speed and carefully enter into the cut moving the tool forward over the workpiece surface. The wheel may bind, walk up or kickback if the power tool is started in the workpiece.

⚠ WARNING: During cutting operations, never change the angle of the wheel. Placing side pressure on the cut-off wheel (as in grinding) will cause the wheel to crack and break, causing serious personal injury.

⚠ WARNING: A diamond wheel shall be operated perpendicular to the material being cut.

Usage example: operation with abrasive cut-off wheel

► Fig.19

Usage example: operation with diamond wheel

► Fig.20

Operation with wire cup brush

Optional accessory

⚠ CAUTION: Check operation of brush by running tool with no load, insuring that no one is in front of or in line with brush.

NOTICE: Avoid applying too much pressure which causes over bending of wires when using the wire cup brush. It may lead to premature breakage.

Usage example: operation with wire cup brush

► Fig.21

Operation with wire wheel brush

Optional accessory

⚠ CAUTION: Check operation of wire wheel brush by running tool with no load, insuring that no one is in front of or in line with the wire wheel brush.

NOTICE: Avoid applying too much pressure which causes over bending of wires when using wire wheel brush. It may lead to premature breakage.

Usage example: operation with wire wheel brush

► Fig.22

MAINTENANCE

CAUTION: Always be sure that the tool is switched off and unplugged before attempting to perform inspection or maintenance.

NOTICE: Never use gasoline, benzene, thinner, alcohol or the like. Discoloration, deformation or cracks may result.

To maintain product SAFETY and RELIABILITY, repairs, carbon brush inspection and replacement, any other maintenance or adjustment should be performed by Makita Authorized or Factory Service Centers, always using Makita replacement parts.

Air vent cleaning

The tool and its air vents have to be kept clean. Regularly clean the tool's air vents or whenever the vents start to become obstructed.

► Fig.23: 1. Exhaust vent 2. Inhalation vent

COMBINATION OF APPLICATIONS AND ACCESSORIES

Optional accessory

CAUTION: Using the tool with incorrect guards can cause risks as follows.

- When using a cut-off wheel guard for facial grinding, the wheel guard may interfere with the work-piece causing poor control.
- When using a grinding wheel guard for cutting-off operations with bonded abrasive wheels and diamond wheels, there is an increased risk of exposure to rotating wheels, emitted sparks and particles, as well as exposure to wheel fragments in the event of wheel burst.
- When using a cut-off wheel guard or grinding wheel guard with a wheel-type wire brush with a thickness greater than the maximum thickness as specified in "SPECIFICATIONS", the wires may catch on the guard leading to breaking of wires.
- Use of dust collecting wheel guards for cutting-off and facial operations in concrete or masonry reduces a risk of exposure to dust.

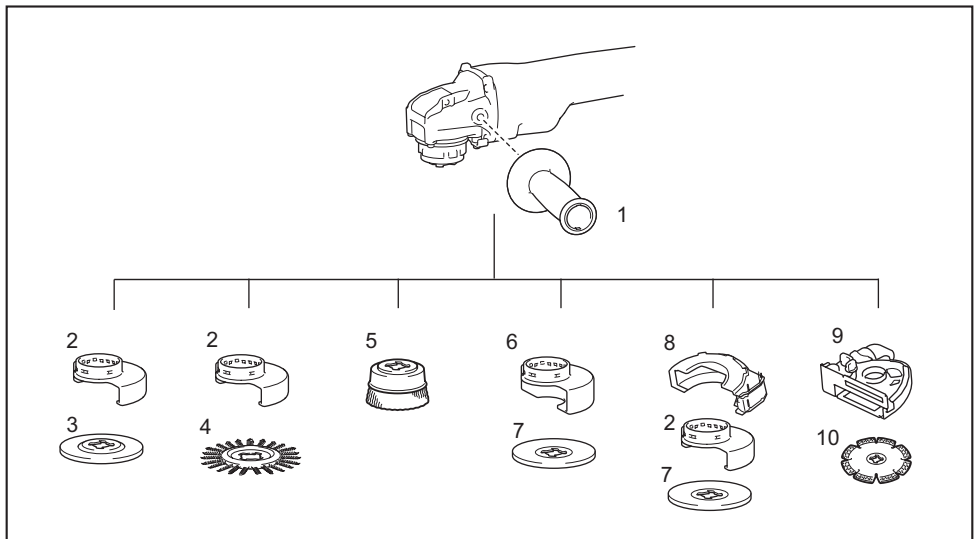

	Application	125 mm model
-		
1	-	Side grip
2	-	Wheel guard (for grinding wheel)
3	Grinding / Sanding	Depressed center wheel / Flap disc
4	Wire brushing	Wire wheel brush

	Application	125 mm model
-	Wire brushing	Wire cup brush
5	-	Wheel guard (for cut-off wheel)
6	Cutting-off	Abrasive cut-off wheel / Diamond wheel
7	-	Clip-on cutting wheel guard attachment *1
8	-	Dust collecting wheel guard for cutting-off *2
9	Cutting-off	Diamond wheel
10	-	Dust cover attachment

NOTE: *1 Clip-on cutting wheel guard attachment is not available in some countries. For more details, refer to the instruction manual of the clip-on cutting wheel guard attachment.

NOTE: *2 For more details, refer to each instruction manual of the guard.

OPTIONAL ACCESSORIES

⚠ CAUTION: These accessories or attachments are recommended for use with your Makita tool specified in this manual. The use of any other accessories or attachments might present a risk of injury to persons. Only use accessory or attachment for its stated purpose.

If you need any assistance for more details regarding these accessories, ask your local Makita Service Center.

- Accessories listed in "COMBINATION OF APPLICATIONS AND ACCESSORIES"

NOTE: Some items in the list may be included in the tool package as standard accessories. They may differ from country to country.